



F11

ANTI-RAM VEHICLE BARRIER



- Mobile anti-ram solution
- Ultra-fast assembly, no tools required
- Easy storage and transport (Rack and Security Box)
- Long life cycle, minimal maintenance
- Fully portable barrier that can be moved for priority vehicles
- Adapts to all surfaces and terrains
- Withstands an impact of 7.5t at 48km/h
- Withstands an impact of 2.5t at 64km/h with the wheels in 'on' position

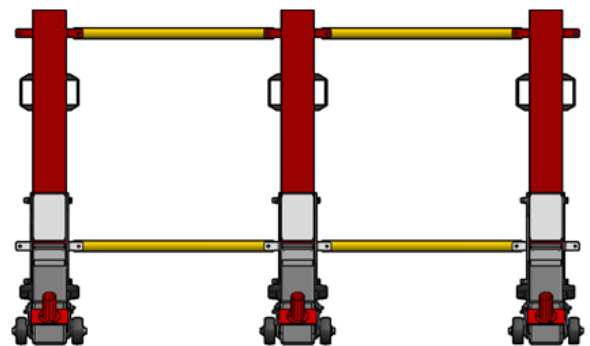

Distance between modules: 80cm

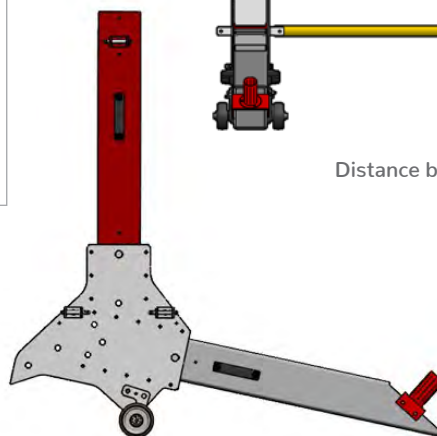

SPECIFICATIONS

HEIGHT	100cm	WIDTH	9.5cm
DEPTH	105cm	WEIGHT	43.8kg

info@turnstar.co.za | www.turnstar.co.za

Turnstar Systems (Pty) Ltd | Reg No: 2012/100536/07 | Established in 1990



JOHANNESBURG HEAD OFFICE AND FACTORY

+27 (0)11 786 1633
18 6th Street, Wynberg,
Sandton, Johannesburg,
South Africa, 2090

WESTERN CAPE BRANCH

+27 (0)21 981 3043
+27 (0)82 417 7408
Unit 9 Elect Park, 13 Teejay
Road, Brackenfell, Cape Town,
South Africa, 7560

KWAZULU NATAL BRANCH

+27 (0)32 947 0391
+27(0)76 589 3410
Unit 5 - 7 Amatuli Industrial Park,
5 - 7 Eagle Road, Shaka's Head,
Umhlali, Kwazulu-Natal,
South Africa, 4420



ISO 9001:2015